

Name	Lillehammer 470x510+VD+Terr/44		
Zeichnung/Drawing	3D		
Profil/Profile	4.4 x 13.5	Datum/Date	03.05.2019

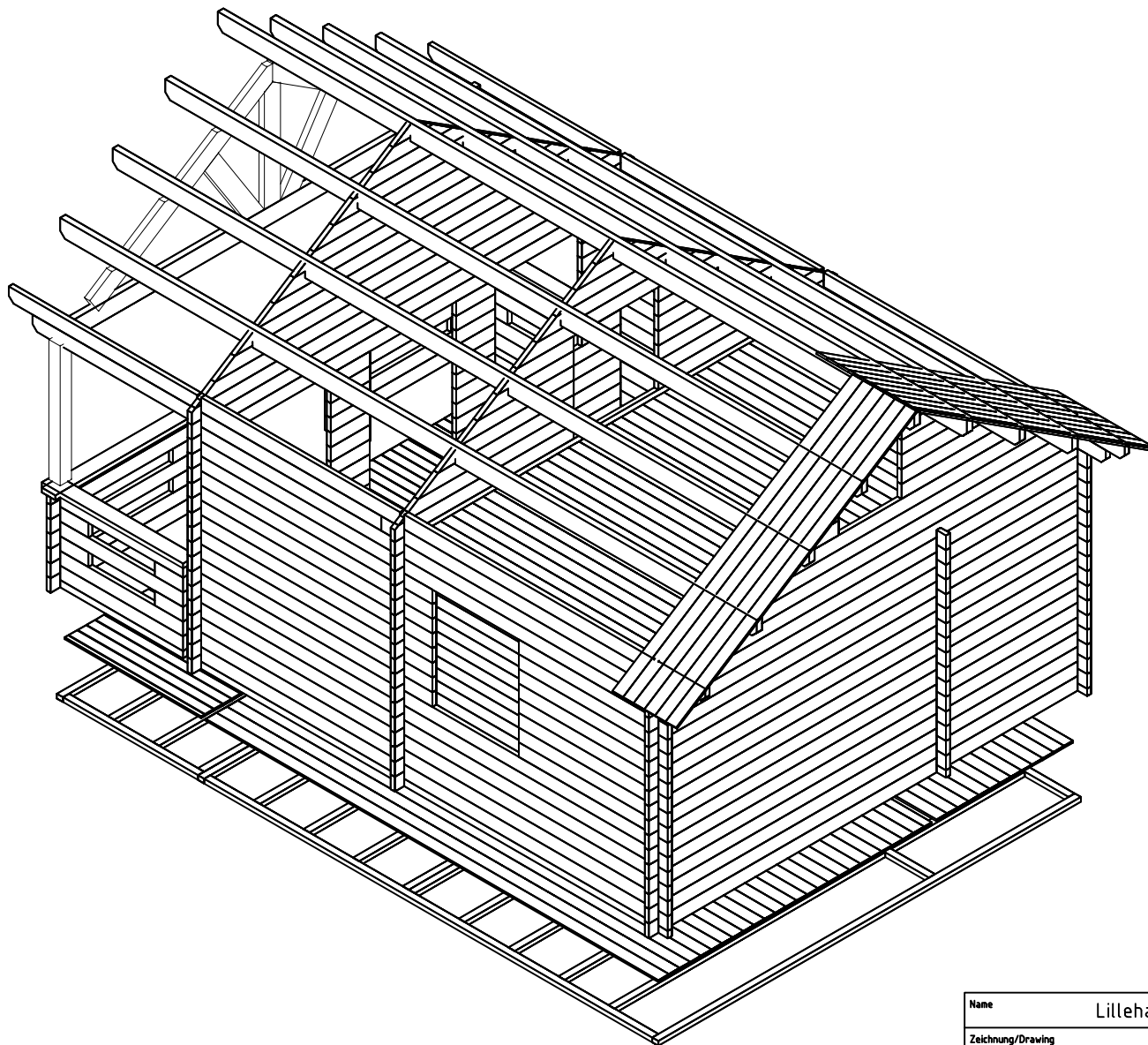

Name	Lillehammer 470x510+VD+Terr/44		
Zeichnung/Drawing	3D		
Profil/Profile	4.4 x 13.5	Datum/Date	15.04.2019

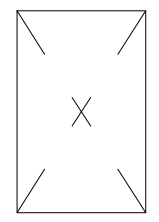
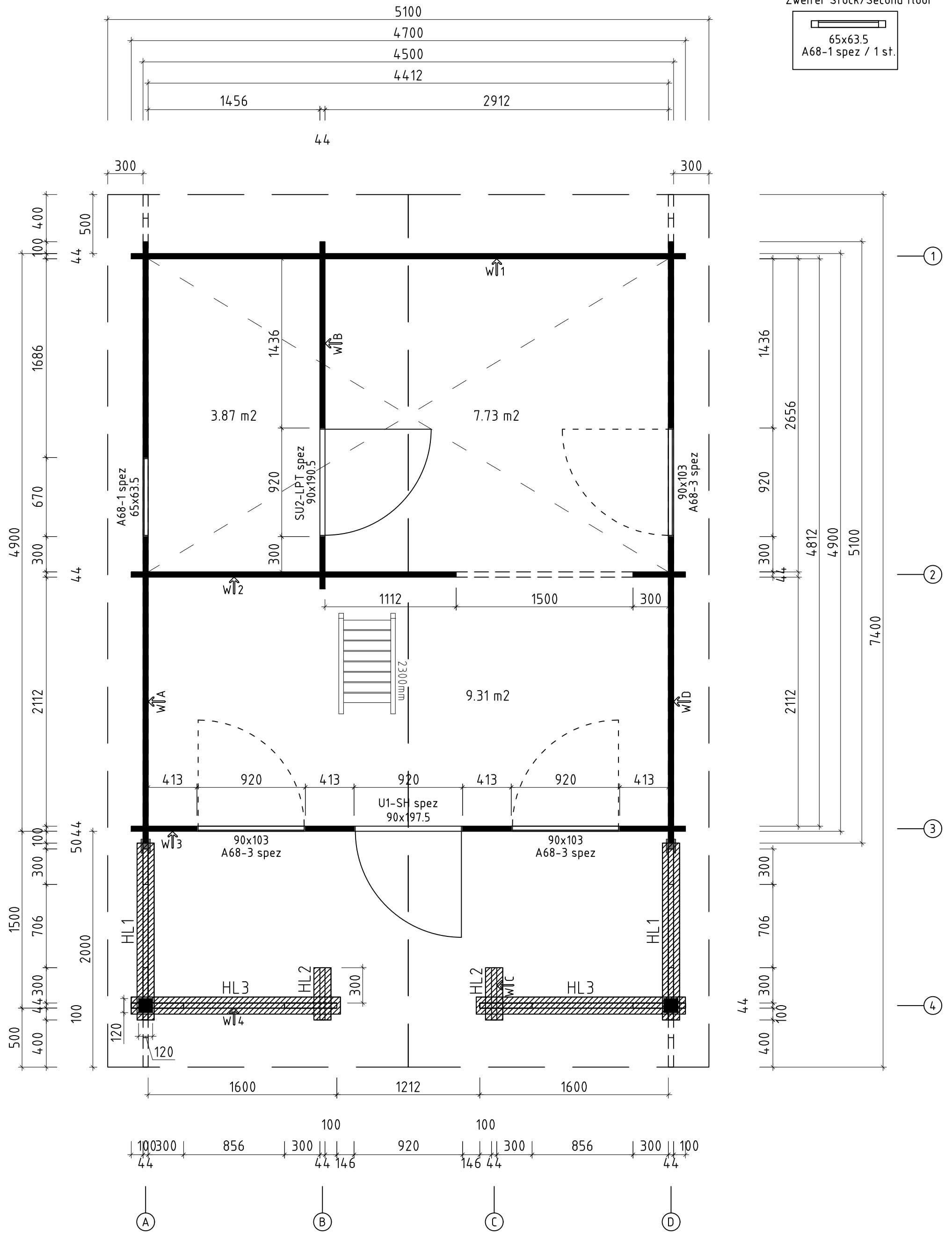
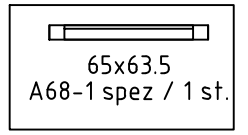

- Schlafboden/sleeping floor

* Fenster und Türen sind mit Sprossen/
Windows and doors are with muntins

Name	Lillehammer 470x510+VD+Terr/44		
Zeichnung/Drawing	Grundplan; Plan		
Profil/Profile	4.4x13.5	Datum/Date	03.05.2019

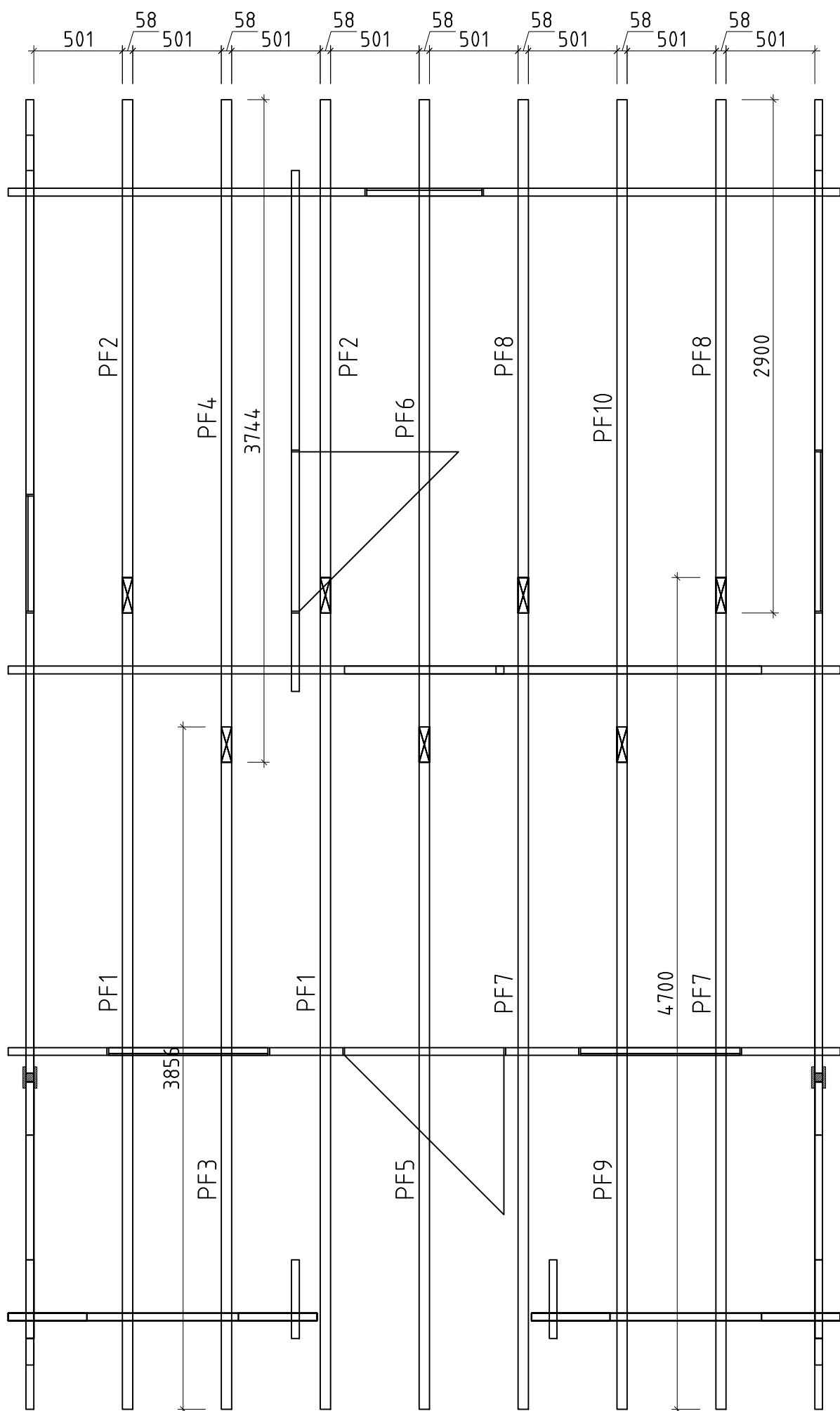

Name	Lillehammer 470x510+VD+Terr/44		
Zeichnung/Drawing	Pfetten; Purlins		
Profil/Profile	4.4x13.5	Datum/Date	03.05.2019

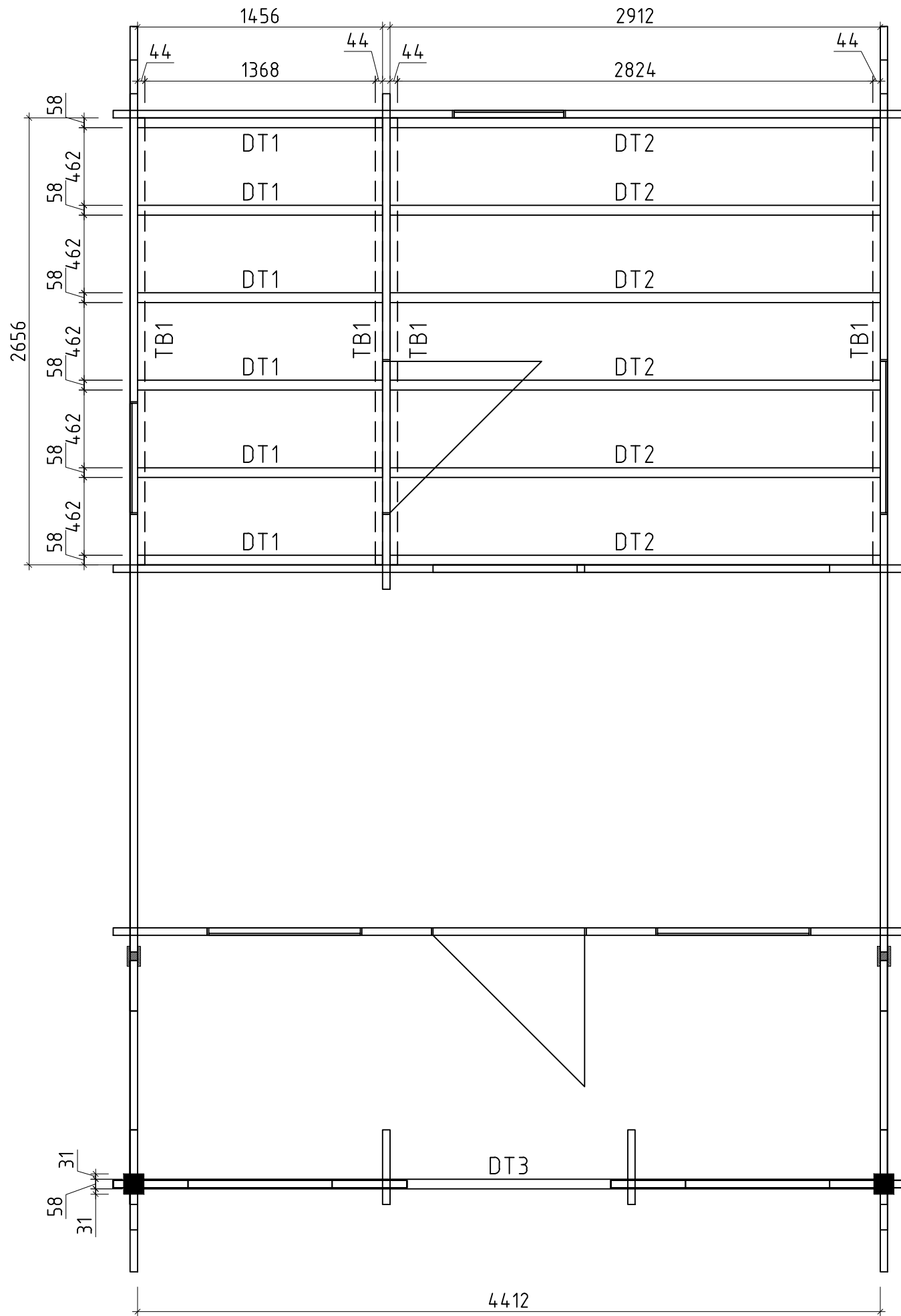

Name	Lillehammer 470x510+VD+Terr/44		
Zeichnung/Drawing	Deckenträger; Cover carrier		
Profil/Profile	4.4x13.5	Datum/Date	03.05.2019

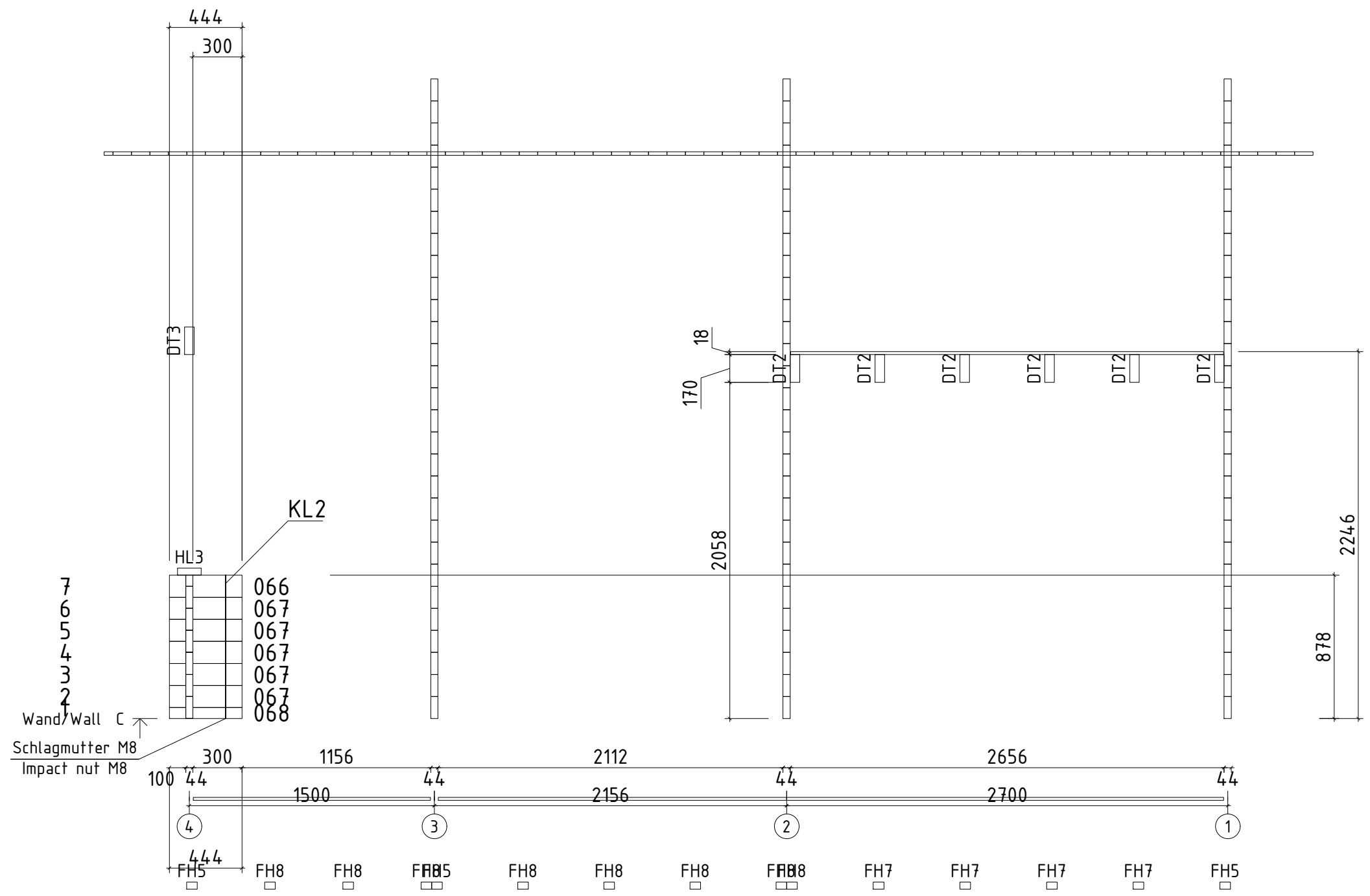

Name	Lillehammer 470x510+VD+Terr/44		
Zeichnung/Drawing	WAND/WALL C		
Profil/Profile	4.4x13.5	Datum/Date	03.05.2019

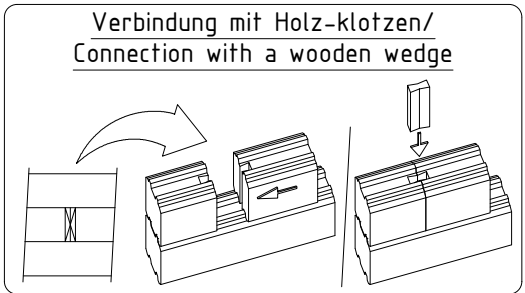
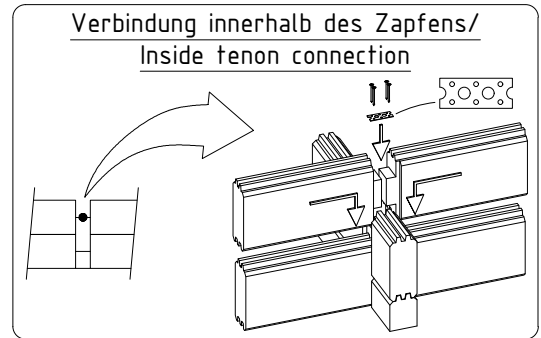
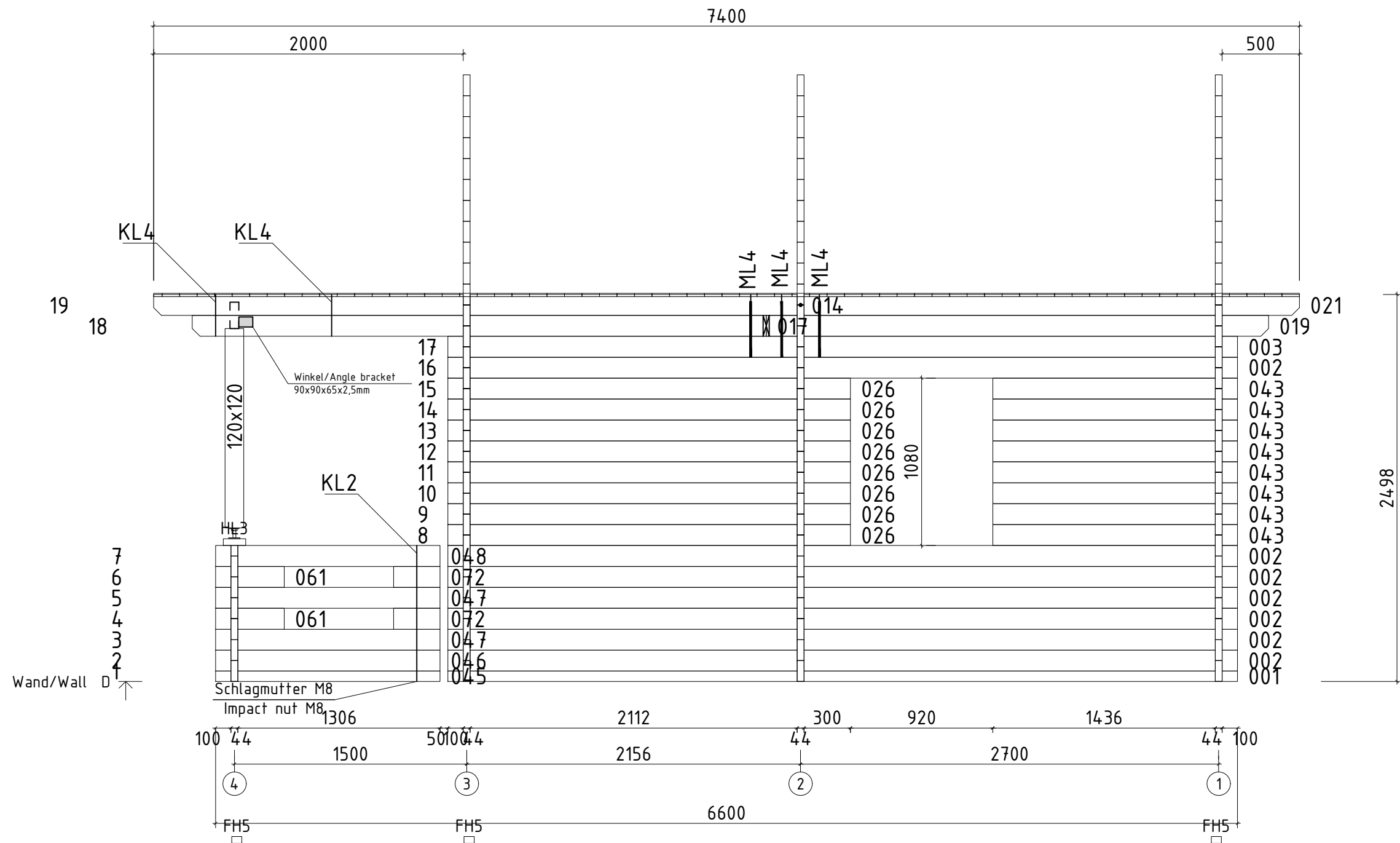

Name	Lillehammer 470x510+VD+Terr/44		
Zeichnung/Drawing	WAND/WALL D		
Profil/Profile	4.4x13.5	Datum/Date	03.05.2019

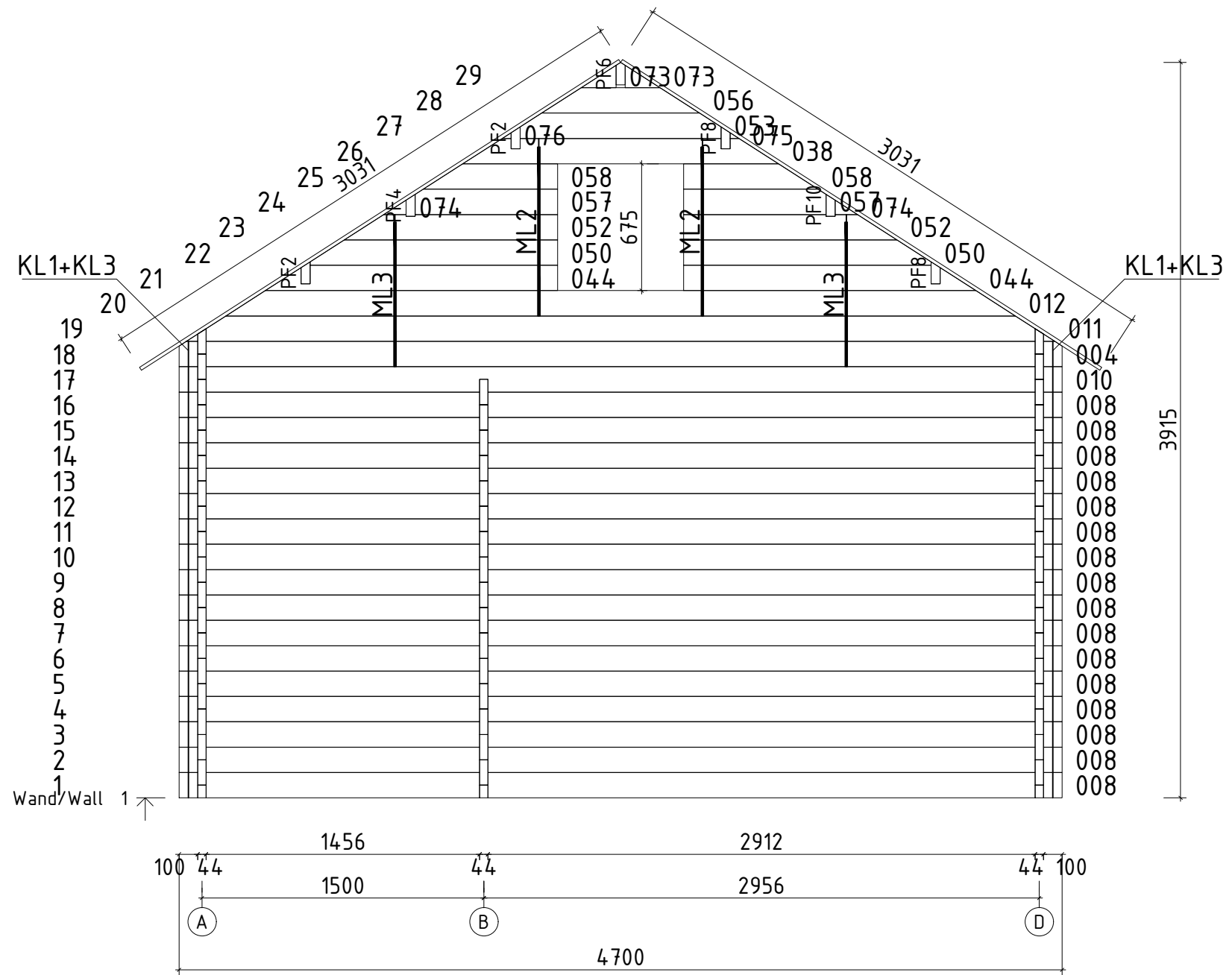

Name	Lillehammer 470x510+VD+Terr/44		
Zeichnung/Drawing	WAND/WALL 1		
Profil/Profile	4.4x13.5	Datum/Date	03.05.2019

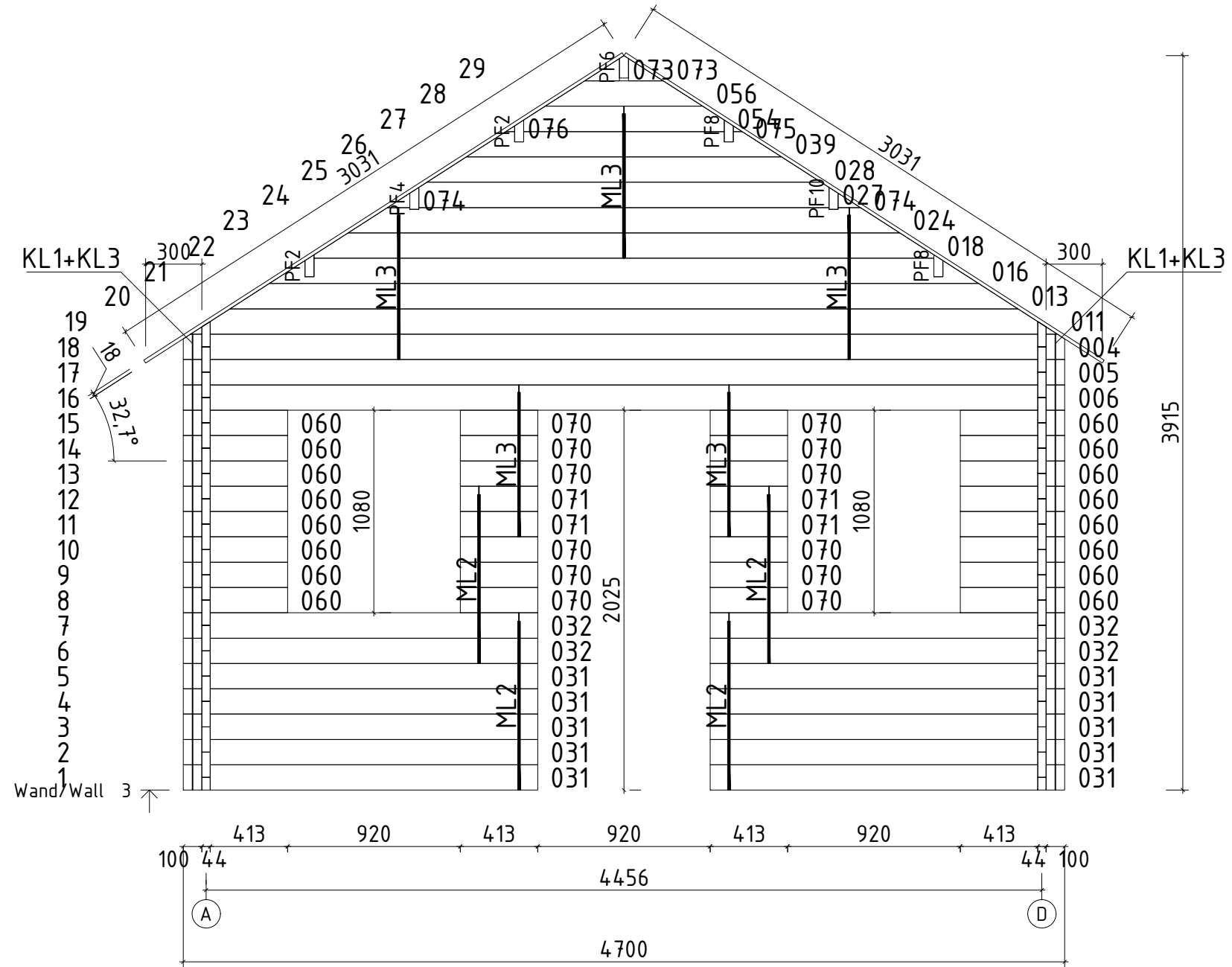
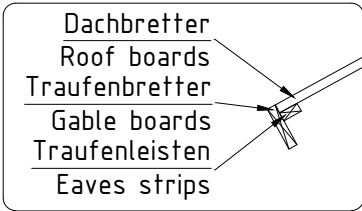



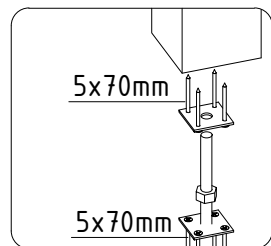
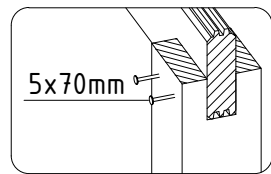
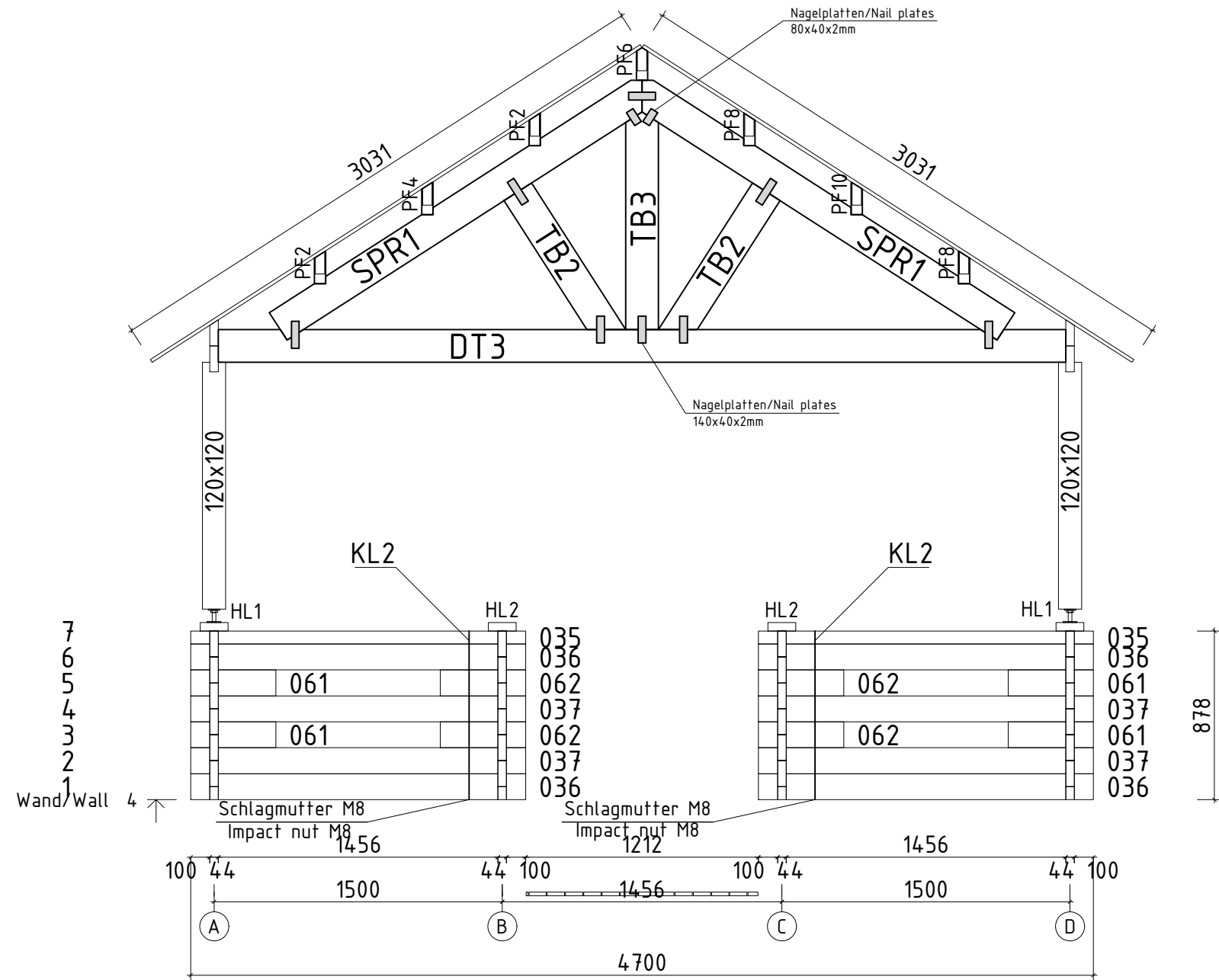





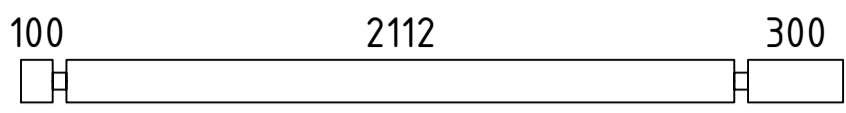
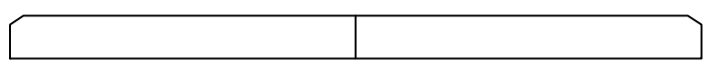
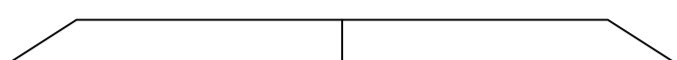
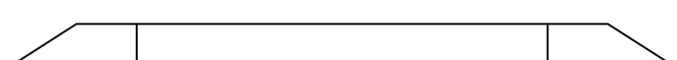
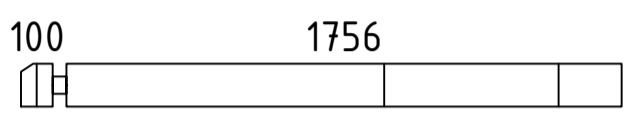
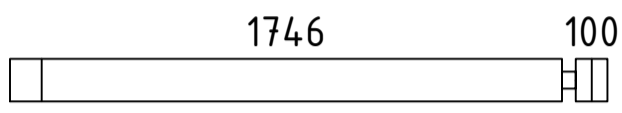
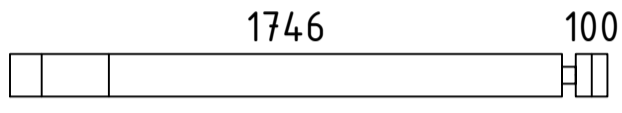
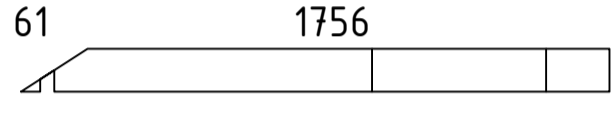
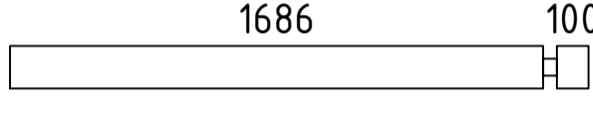
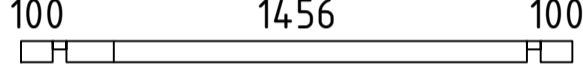
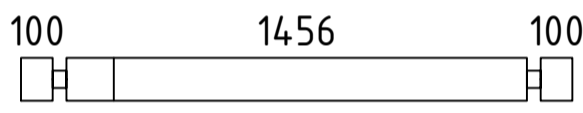
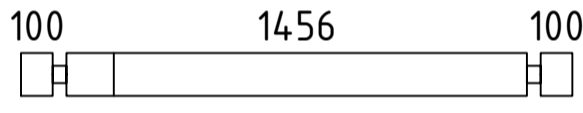
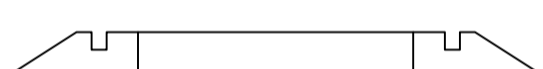
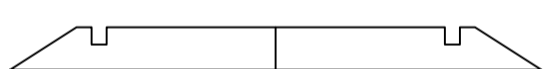
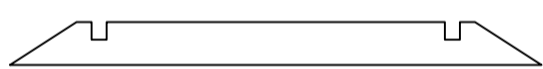
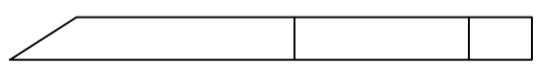
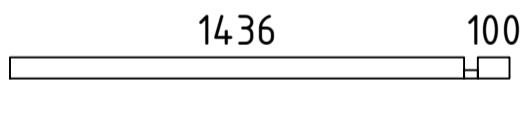
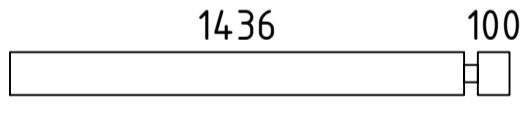
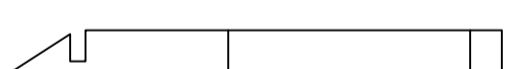
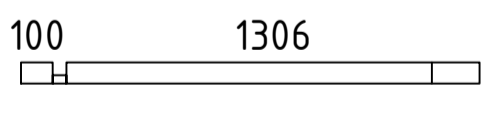
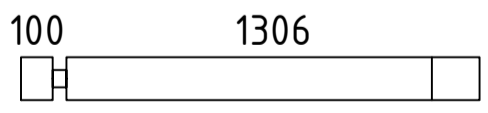
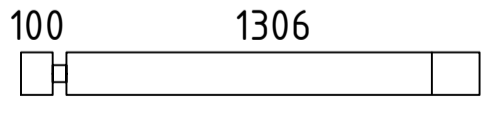
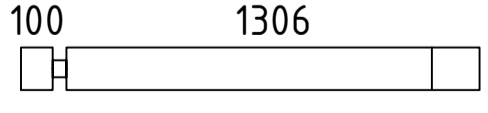
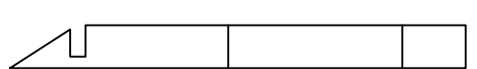
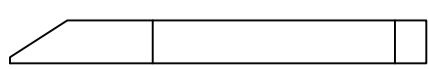

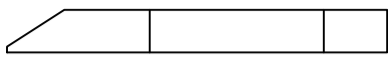
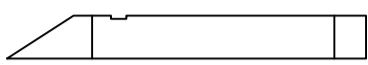
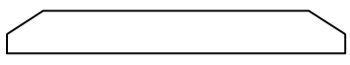
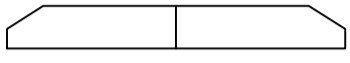

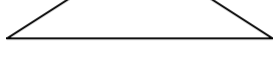

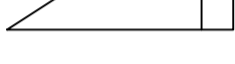
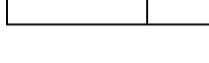
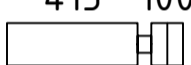
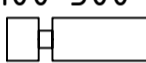
Name	Lillehammer 470x510+VD+Terr/44		
Zeichnung/Drawing	WAND/WALL 3		
Profil/Profile	4.4x13.5	Datum/Date	03.05.2019

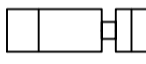
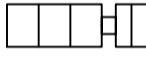



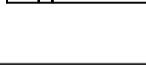
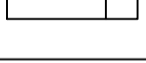
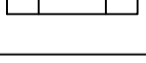
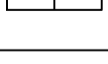





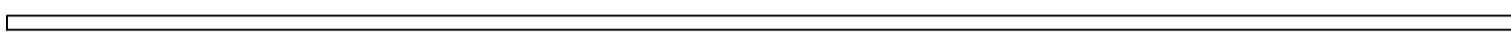
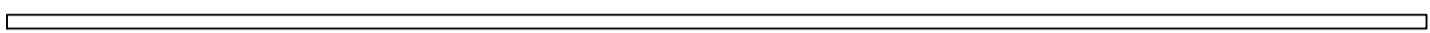
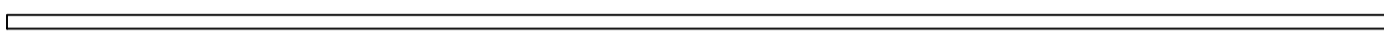
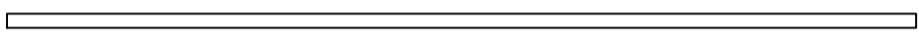
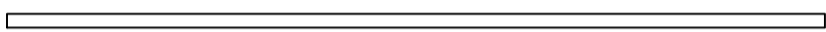
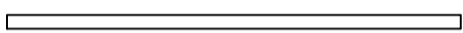
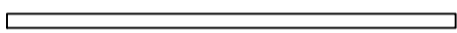
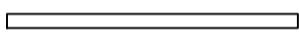
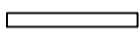

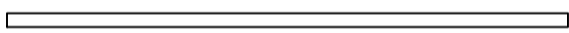
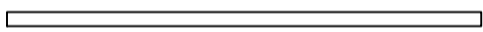
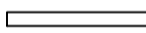

Name	Lillehammer 470x510+VD+Terr/44		
Zeichnung/Drawing	WAND/WALL 4		
Profil/Profile	4.4x13.5	Datum/Date	03.05.2019

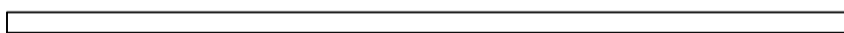



Pos	Teileliste/Specification Lillehammer 470x510+VD+Terr/44	Stck. Pcs.	Profil Profile (mm)	Länge Length (mm)
001		2	44x68	5100
002		17	44x135	5100
003		2	44x135	5100
004		2	44x135	4700
005		1	44x135	4700
006		1	44x135	4700
007		1	44x135	4700
008		17	44x135	4700
009		1	44x135	4700
010		1	44x135	4700
011		2	44x135	4622
012		1	44x135	4202
013		1	44x135	4202
014		1	44x135	4178
015		1	44x135	4178
016		1	44x135	3782
017		2	44x135	3706
018		1	44x135	3305
019		2	44x135	3244
020		1	44x135	3222
021		1	44x135	3222
022		1	44x135	2944
023		1	44x135	2944
024		1	44x135	2941
025		14	44x135	2756

Pos	Teileliste/Specification Lillehammer 470x510+VD+Terr/44	Stck. Pcs.	Profil Profile (mm)	Länge Length (mm)
026		13	44x135	2600
027		1	44x135	2187
028		1	44x135	2101
029		1	44x135	2101
030		2	44x135	1900
031		10	44x135	1890
032		4	44x135	1890
033		2	44x135	1861
034		5	44x135	1830
035		2	44x68	1744
036		4	44x135	1744
037		4	44x135	1744
038		1	44x135	1681
039		1	44x135	1681
040		1	44x135	1681
041		2	44x135	1651
042		1	44x68	1580
043		22	44x135	1580
044		2	44x135	1556
045		2	44x68	1450
046		2	44x135	1450
047		4	44x135	1450
048		2	44x135	1450
049		2	44x135	1441
050		2	44x135	1317

Pos	Teileliste/Specification Lillehammer 470x510+VD+Terr/44	Stck. Pcs.	Profil Profile (mm)	Länge Length (mm)
051		2	44x135	1202
052		2	44x135	1136
053		2	44x135	1070
054		1	44x135	1070
055		2	44x135	1021
056		3	44x135	840
057		2	44x135	759
058		2	44x135	715
059		2	44x135	644
060	413 100 	16	44x135	557
061	100 300 	22	44x135	444
062	100 300 	4	44x135	444
063	300 100 	7	44x135	444
064	300 100 	4	44x135	444
065	300 100 	3	44x135	444
066	100 300 	2	44x135	444
067	100 300 	10	44x135	444
068	100 300 	2	44x68	444
069	100 300 	1	44x68	444
070		12	44x135	413
071		4	44x135	413
072		4	44x135	300
073		6	44x120	186
074		6	44x77	119
075		3	44x31	48

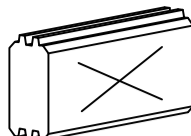
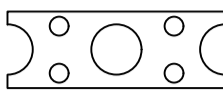
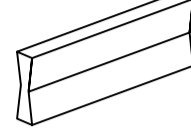
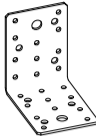
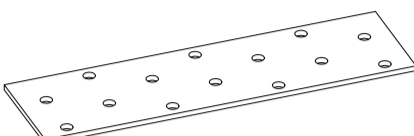
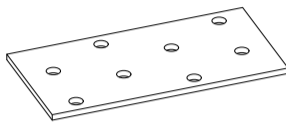
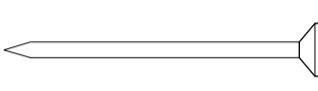
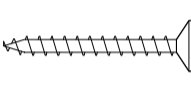
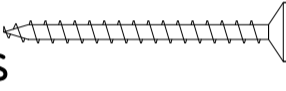
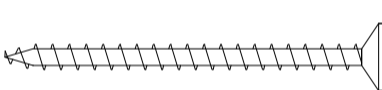
Pos	Teileliste/Specification Lillehammer 470x510+VD+Terr/44			Stck. Pcs.	Profil Profile (mm)	Länge Length (mm)
076				3	44x31	48
FH2	FUNDAMENTHOLZ (imprägniert) - FOUNDATION BEAM (impregnated) 			2	65x44	4760
FH5	FUNDAMENTHOLZ (imprägniert) - FOUNDATION BEAM (impregnated) 			3	65x44	4490
FH8	FUNDAMENTHOLZ (imprägniert) - FOUNDATION BEAM (impregnated) 			8	65x44	4360
FH7	FUNDAMENTHOLZ (imprägniert) - FOUNDATION BEAM (impregnated) 			4	65x44	2875
FH4	FUNDAMENTHOLZ (imprägniert) - FOUNDATION BEAM (impregnated) 			1	65x44	2587
FH1	FUNDAMENTHOLZ (imprägniert) - FOUNDATION BEAM (impregnated) 			2	65x44	1435
FH6	FUNDAMENTHOLZ (imprägniert) - FOUNDATION BEAM (impregnated) 			4	65x44	1420
FH9	FUNDAMENTHOLZ (imprägniert) - FOUNDATION BEAM (impregnated) 			1	65x44	920
FH3	FUNDAMENTHOLZ (imprägniert) - FOUNDATION BEAM (impregnated) 			2	65x44	413
DT3	DECKENTRÄGER - COVER CARRIER 			1	58x170	4410
DT2	DECKENTRÄGER - COVER CARRIER 			6	58x170	2910
DT1	DECKENTRÄGER - COVER CARRIER 			6	58x170	1456
HL3	HANDLAUF - HANDRAIL 			2	145x44	1774
HL1	HANDLAUF - HANDRAIL 			2	145x44	1500
HL2	HANDLAUF - HANDRAIL 			2	145x44	444
TB3	TRÄGEBALKE - SUPPORT BEAM 			1	58x170	1133
TB2	TRÄGEBALKE - SUPPORT BEAM 			2	58x170	907
TB1	TRÄGEBALKE - SUPPORT BEAM 			4	44x65	2655
SPR1	SPARREN - RAFTERS 			2	58x170	2286
PF7	2000 PFETTEN - PURLINS 2112 500 			2	58x170	4700
PF1	2000 PFETTEN - PURLINS 2112 500 			2	58x170	4700
PF9	2000 PFETTEN - PURLINS 1812 			1	58x170	3856
PF3	2000 PFETTEN - PURLINS 1812 			1	58x170	3856
PF5	2000 PFETTEN - PURLINS 1812 			1	58x170	3856
Kood	Lillehammer 470x510+VD+Terr/44			File	Lillehammer 470x510+VD+Terr/44.dwg	

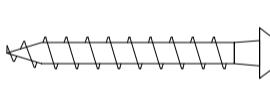
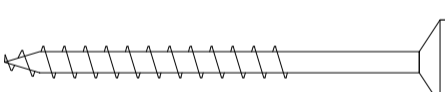
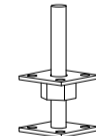
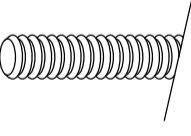
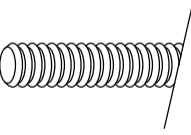
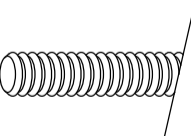
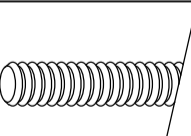
Pos	Teilleiste/Specification Lillehammer 470x510+VD+Terr/44		Stck. Pcs.	Profil Profile (mm)	Länge Length (mm)
PF4		PFETTEN - PURLINS	1	58x170	3744
PF6		PFETTEN - PURLINS	1	58x170	3744
PF10		PFETTEN - PURLINS	1	58x170	3744
PF2		PFETTEN - PURLINS	2	58x170	2900
PF8		PFETTEN - PURLINS	2	58x170	2900
	DACHBRETTER - ROOF BOARDS		132+2	113x18	3030
	FUSSBODENBRETTER - FLOOR BOARDS		26+1	113x18	4805
	FUSSBODENBRETTER - FLOOR BOARDS		13	113x18	2650
	FUSSBODENBRETTER - FLOOR BOARDS		13	113x18	2107
	SCHLAFBODENBRETTER - SLEEPING FLOOR BOARDS		39+1	113x18	2650
	TERRASSENBRETTER (imprägniert) - TERRACE BOARDS (impregnated)		14+1	90x18	1495
	TERRASSENBRETTER (imprägniert) - TERRACE BOARDS (impregnated)		33	90x18	1450
	FUSSBODENLEISTEN - FLOOR STRIPS	✓		18x40	45,0 lfm/rm
G02-1	GIEBELBRETTER - GABLE BOARDS 18x120	32,7° ✓	4	18x120	3110
G06-1	GIEBELDECKLEISTEN - GABLE COVER STRIPS 18x58	✓	4	18x58	3110
GS	GIEBELSEGMENT - GABLE DIAMOND		2		
T01-1	TRAUFENBRETTER - EAVES BOARDS 18x90		4	18x90	3700
T06-1	TRAUFENLEISTEN - EAVES STRIPS 18x40	✓		18x40	15,0 lfm/rm
UP3-1	U-PROFIL - U-PROFILE 44	✓	2	44x65	960
UP3-2	U-PROFIL - U-PROFILE 44	✓	2	44x65	1005
TP1 20-1	STÜTZPFOSTE - SUPPORT POST 120x120	✓	2	120x120	1330
ML1	Metallstange - Metal bar		2	D10	1170
ML2	Metallstange - Metal bar		7	D10	900
ML3	Metallstange - Metal bar		11	D10	770
ML4	Metallstange - Metal bar		6	D10	360
Kood	Lillehammer 470x510+VD+Terr/44	Material	File	Lillehammer 470x510+VD+Terr/44.dwg	7

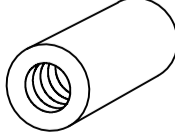
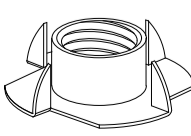
Pos	Teilleiste/Specification Lillehammer 470x510+VD+Terr/44		Stck. Pcs.	Profil Profile (mm)	Länge Length (mm)
SH	SCHLAGHÖLZER - MOUNTING PIECES		3		
VS	Verbindungsstreifen für verbinden der Wandbohlen - Connecting strip for connecting the wall parts		2		
HK2	HOLZ-KLOTZEN für verbinden der Wandbohlen - Wooden wedge for connecting the wall parts (122mm)		2		
W05	Winkel - Angle bracket 90x90x65 DT3		2		
NP04	NAGELPLATTEN - NAIL PLATES 40x140 SPR1, TB2, TB3		16		
NP03	NAGELPLATTEN - NAIL PLATES 40x80 SPR1, TB2, TB3		4		
NG04	NÄGEL - NAILS 2.5x50 Dachbretter - Roof boards Fussbodenbretter - Floor boards Schlafbodenbretter - Sleeping floor boards Terrassenbretter - Terrace boards		3022		
SR32	Schrauben - Screws 3.0x30 Traufenleiste - Eaves strips Fussbodenleiste - Floor strips		120		
SR37	Schrauben - Screws 3.5x45 Giebelbretter - Gable boards Giebeldeckleisten - Gable cover strips Giebelsegment - Gable diamond Traufenbretter - Eaves boards Handlauf - Handrail U-Profil - U-Profile Fenster- und Türleisten - Window and door strips Verbindungsstreifen - Connecting strips		288		
SR44	Schrauben - Screws 4.0x60 Wasserleiste - Rain strip WL1		16		
SR57	Schrauben - Screws 5.0x100 Fundamenthölzer - Foundation beams		108		
SR52	Schrauben - Screws 5.0x42 Winkel - Angle bracket Nagelplatten - Nail plates		176		
SR55	Schrauben - Screws 5.0x70 TB1, DT1, DT2 Stützpfole - Support post		92		
VP3	Verstellbare Pfostenstütze - Adjustable post support M20		2		
KL1	Gewindestange - Threaded Rod M8		6		2000
KL2	Gewindestange - Threaded Rod M8		6		878
KL3	Gewindestange - Threaded Rod M8		6		460
KL4	Gewindestange - Threaded Rod M8		4		270
	Mutter - Nut M8		26		
	U-Scheibe - Washer M8 Ø25		26		
	Befestigungsmutter - Fixing nut M8		6		
LMT01	Schlagmutter - Impact nut M8		6		
Kood	Lillehammer 470x510+VD+Terr/44	Material	File	Lillehammer 470x510+VD+Terr/44.dwg	7

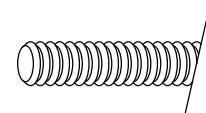
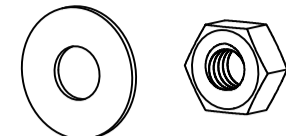
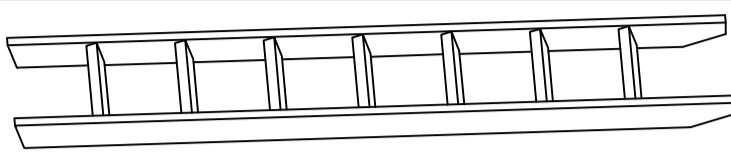
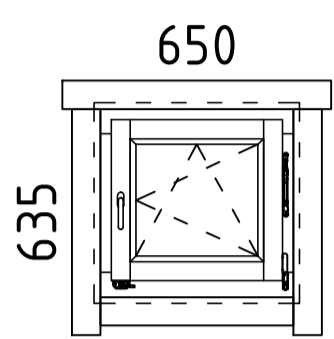
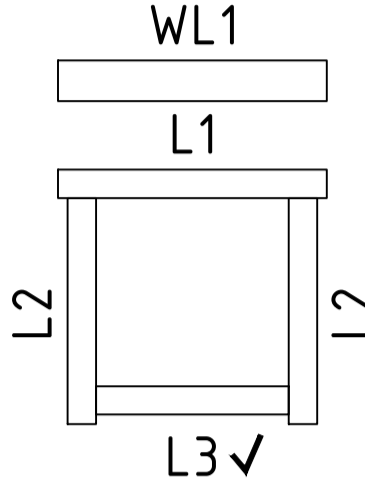
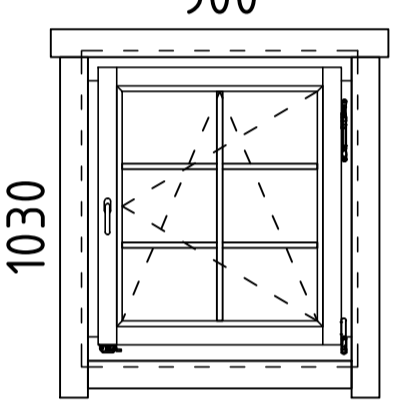
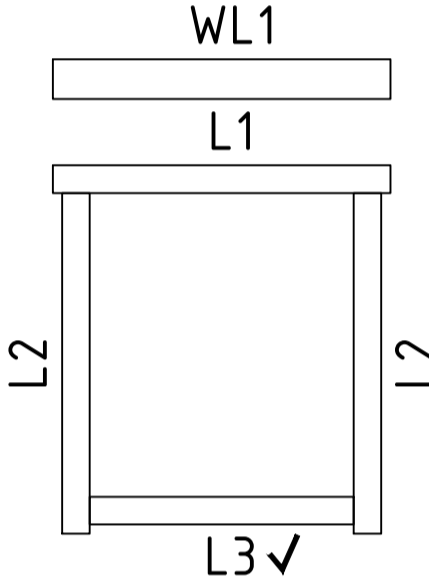
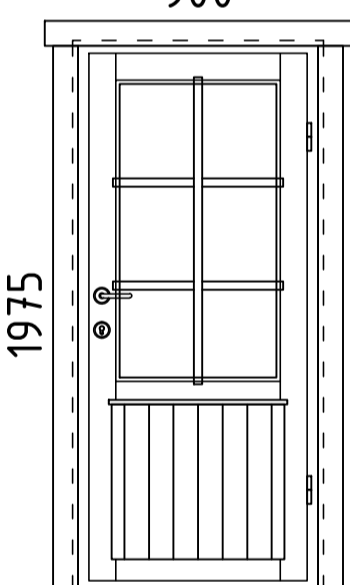
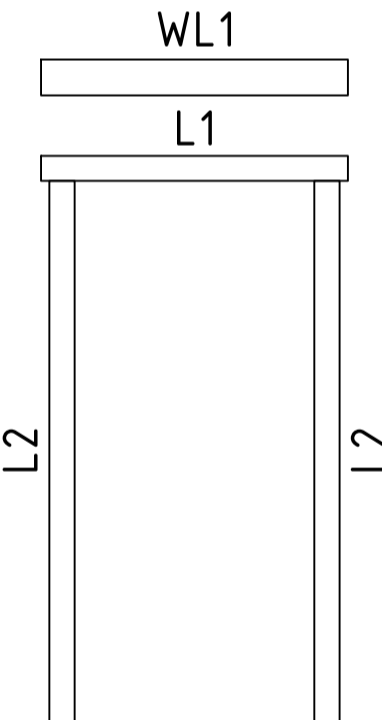
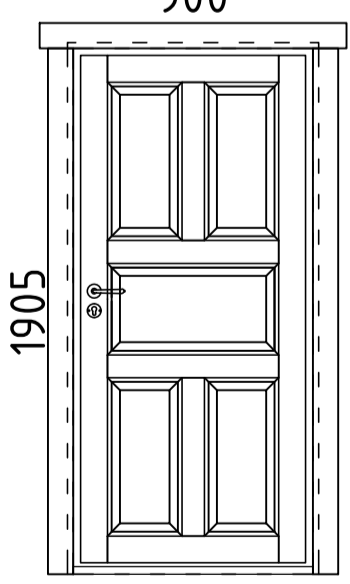
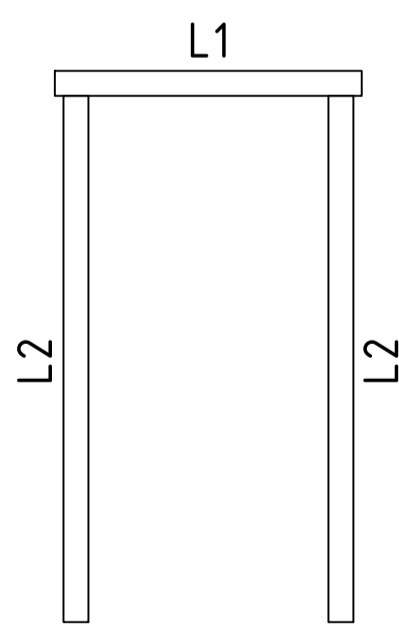
Pos	Teileliste/Specification Lillehammer 470x510+VD+Terr/44	Stck. Pcs.	Profil Profile (mm)	Länge Length (mm)																
KL-1	Gewindestange - Threaded rod M12- für die Pfetten - for purlins 	14		170																
MUT26	Mutter - Nut M12 U-Scheibe - Washer Ø30- für die Pfetten - for purlins 	28																		
TR01-1	LEITER - LADDER 2300mm 	1		2300																
	FENSTER/WINDOW 650x635   <p>A68-1 spec (Q4)</p> <table border="0"> <tr> <td>L1</td> <td>18x90</td> <td>L=850mm</td> <td>2*</td> </tr> <tr> <td>L2</td> <td>18x90</td> <td>L=715mm</td> <td>4*</td> </tr> <tr> <td>L3</td> <td>18x90</td> <td>L=610mm</td> <td>2* ✓</td> </tr> <tr> <td>WL1</td> <td>36x129</td> <td>L=850mm</td> <td>1*</td> </tr> </table>	L1	18x90	L=850mm	2*	L2	18x90	L=715mm	4*	L3	18x90	L=610mm	2* ✓	WL1	36x129	L=850mm	1*	2		
L1	18x90	L=850mm	2*																	
L2	18x90	L=715mm	4*																	
L3	18x90	L=610mm	2* ✓																	
WL1	36x129	L=850mm	1*																	
	FENSTER/WINDOW 900x1030   <p>A68-3 spec (Q4)</p> <table border="0"> <tr> <td>L1</td> <td>18x90</td> <td>L=1100mm</td> <td>2*</td> </tr> <tr> <td>L2</td> <td>18x90</td> <td>L=1110mm</td> <td>4*</td> </tr> <tr> <td>L3</td> <td>18x90</td> <td>L=860mm</td> <td>2* ✓</td> </tr> <tr> <td>WL1</td> <td>36x129</td> <td>L=1100mm</td> <td>1*</td> </tr> </table> <p>DIN 1xrechts/right handed, 2xlinks/left handed</p>	L1	18x90	L=1100mm	2*	L2	18x90	L=1110mm	4*	L3	18x90	L=860mm	2* ✓	WL1	36x129	L=1100mm	1*	3		
L1	18x90	L=1100mm	2*																	
L2	18x90	L=1110mm	4*																	
L3	18x90	L=860mm	2* ✓																	
WL1	36x129	L=1100mm	1*																	
	TÜR/DOOR 900x1975   <p>U1-SH spec (Q4)</p> <table border="0"> <tr> <td>L1</td> <td>18x90</td> <td>L=1100mm</td> <td>2*</td> </tr> <tr> <td>L2</td> <td>18x90</td> <td>L=1955mm</td> <td>4* ✓</td> </tr> <tr> <td>WL1</td> <td>36x129</td> <td>L=1100mm</td> <td>1*</td> </tr> </table> <p>DIN rechts/ right handed</p>	L1	18x90	L=1100mm	2*	L2	18x90	L=1955mm	4* ✓	WL1	36x129	L=1100mm	1*	1						
L1	18x90	L=1100mm	2*																	
L2	18x90	L=1955mm	4* ✓																	
WL1	36x129	L=1100mm	1*																	
	TÜR/DOOR 900x1905   <p>SU2_LPT spec (Q4)</p> <table border="0"> <tr> <td>L1</td> <td>18x90</td> <td>L=1100mm</td> <td>2x</td> </tr> <tr> <td>L2</td> <td>18x90</td> <td>L=1885mm</td> <td>4x ✓</td> </tr> </table> <p>DIN rechts/right handed</p>	L1	18x90	L=1100mm	2x	L2	18x90	L=1885mm	4x ✓	1										
L1	18x90	L=1100mm	2x																	
L2	18x90	L=1885mm	4x ✓																	
	✓ - Bitte selber anpassen (falls nötig)! / Cut into length on site (if needed)!																			

Akna tüüp / Fenster typ / Window type - A68
(GH+ / SH)

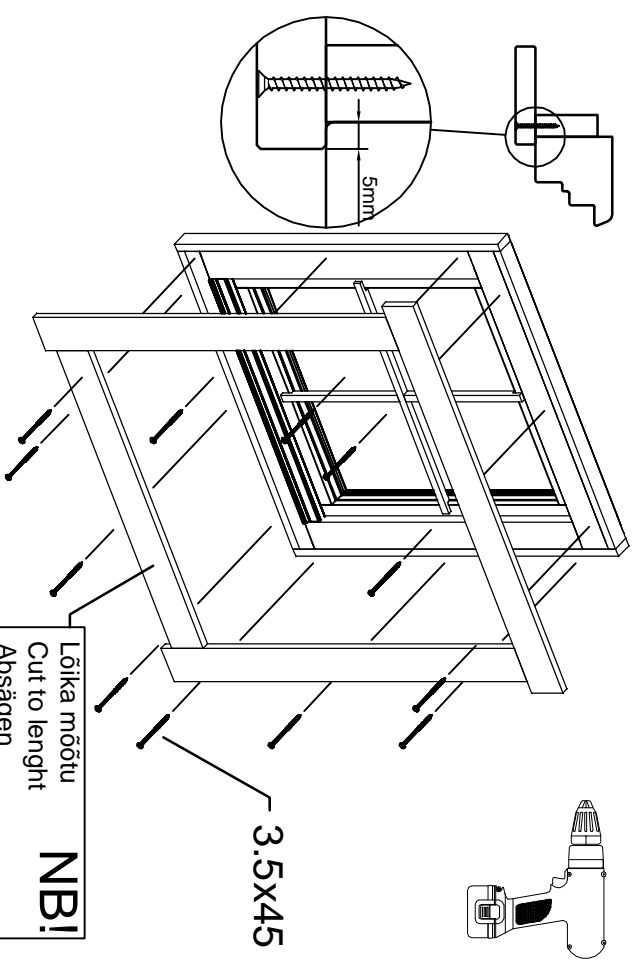
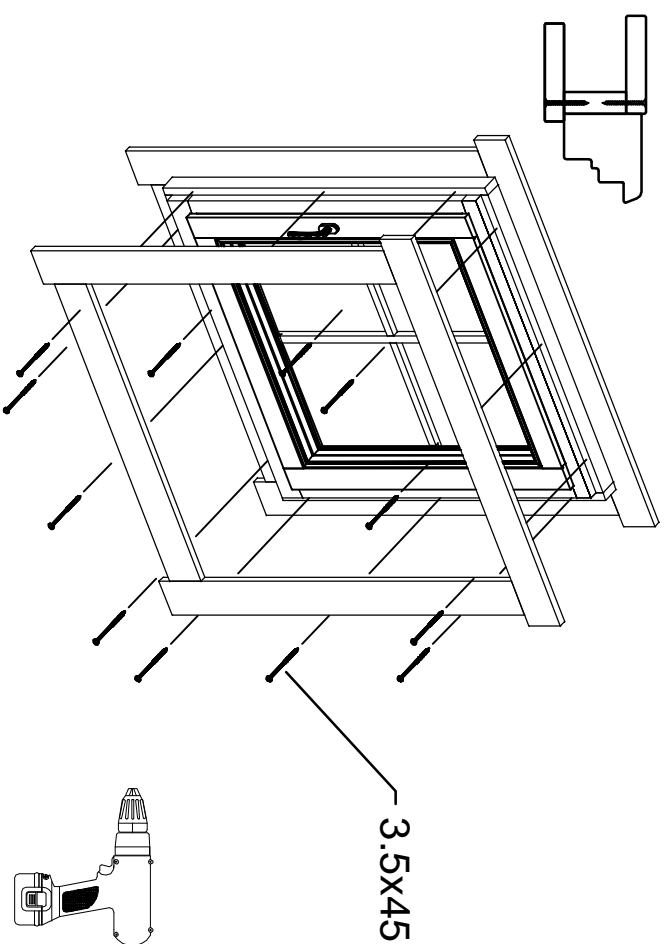
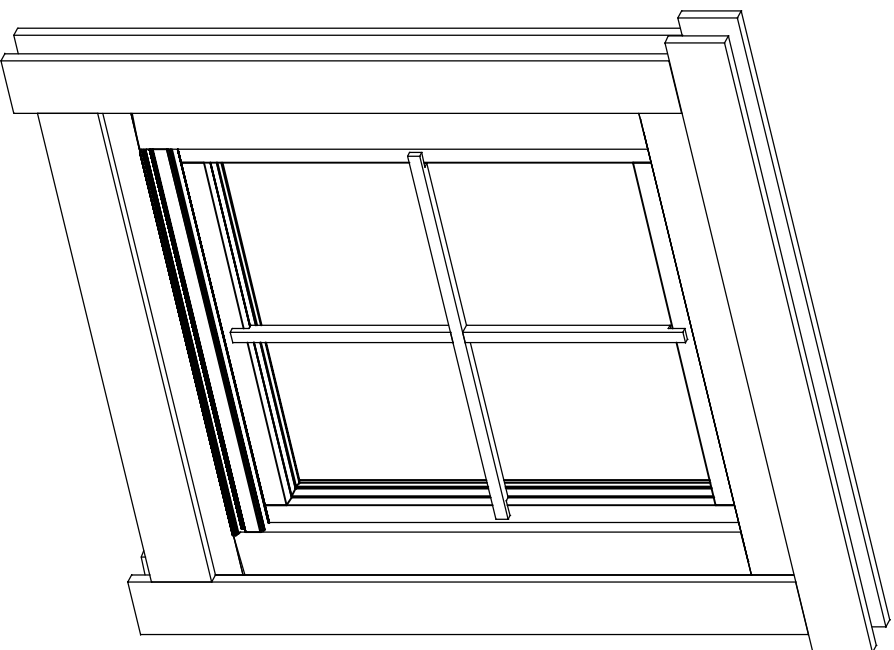

Vihmaliist / Rain strip / Wasserleiste

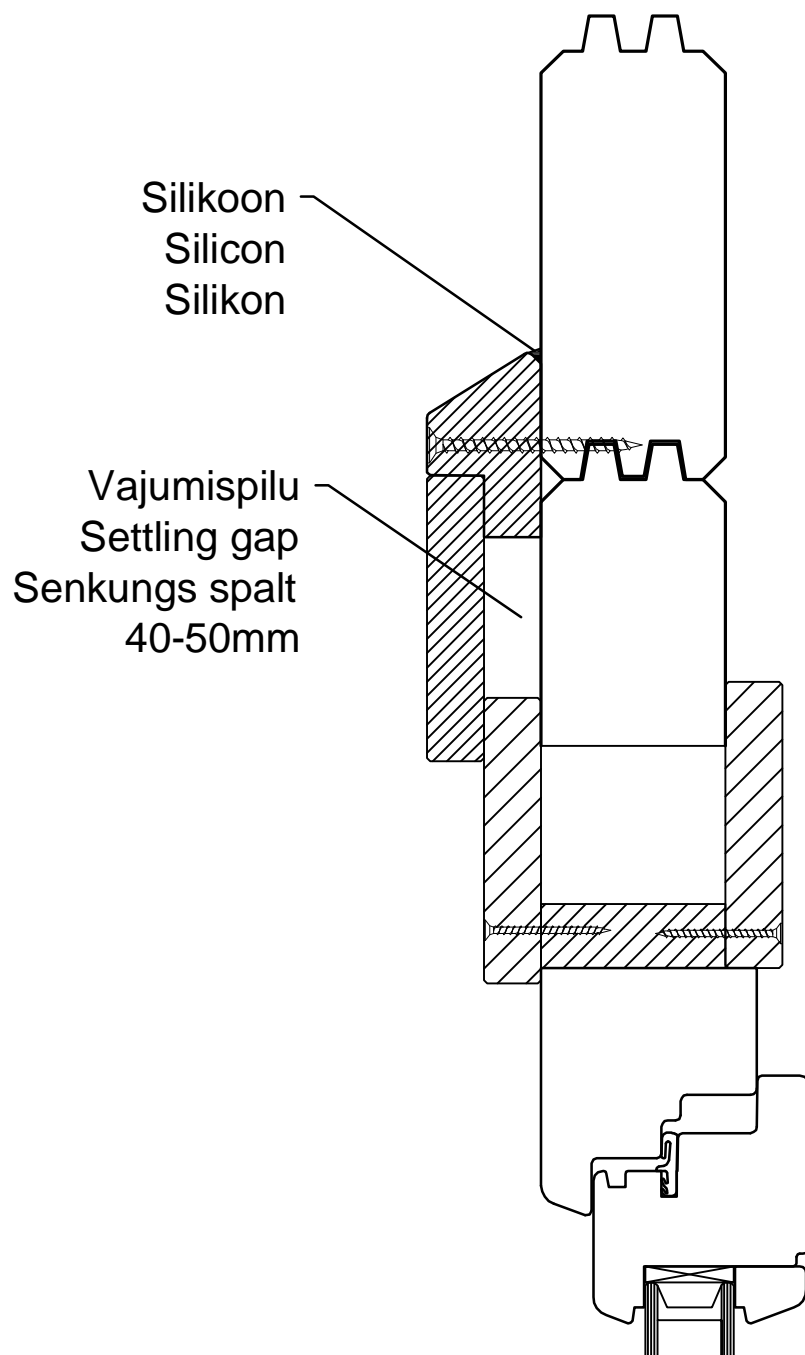

NB!

- Monteerida juhul kui ese on välja toodud maja spetsifikatsioonis!
- Install only if the item is listed in the house specification!
- Nur montieren wenn die Leiste in der Teileliste gezeigt ist!

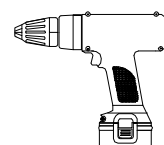

Vihmaliist / Head flashing / Regenschutz

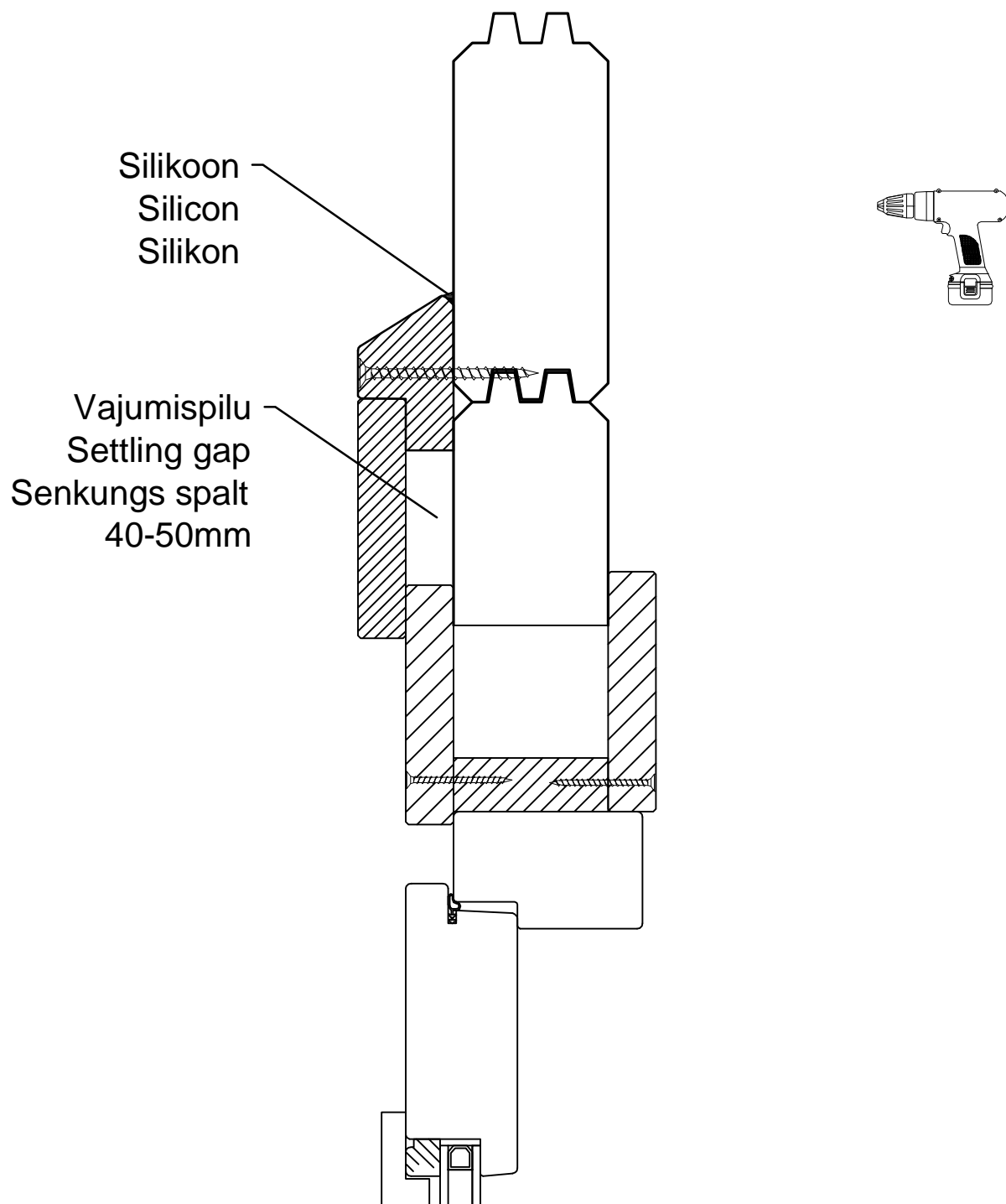

NB!

- Monteerida juhul kui ese on välja toodud maja spetsifikatsioonis!
- Install only if the item is listed in the house specification!
- Nur montieren wenn die Leiste in der Teileliste gezeigt ist!

Ukse montaa 0 / Tür montage / Door assembly
(GH+ / SH)

